



# Add A New Function To Your Machine - Automatic Marking Without 2nd Operations.

*An Easy, Efficient & Economical Solution To  
Mark A Part While Still Set Up In The Machine.*



The NEW Tapmatic Marking Head works on CNC machining and turning centers as well as any manual turning, milling or drilling machines and is easily positioned in tool magazine or turret without interfering with machine components or workpiece.

- ✓ Marks In Less Than 1 Second.
- ✓ Adjustable and Uniform Marking Depth.
- ✓ Precise Marking Location Repeatability.
- ✓ Easy Type Changes.
- ✓ Holds Up To 15 Characters or A Custom Stamp.



Send For  
FREE  
Video CD  
Or Visit  
[tapmatic.com](http://tapmatic.com)  
For Information  
On The New  
Marking Head  
And Complete  
Tapmatic  
Tapping Program.

## **TAPMATIC**

ISO 9001 CERTIFIED: 802 Clearwater Loop, Post Falls, ID 83854, Phone: 800/854-6019, FAX: 208-773-3021, E-Mail: [info@tapmatic.com](mailto:info@tapmatic.com)

# New Marking Head For In-Machine Marking

## Without 2nd Operations

Carousel Accessibility of the TAPMATIC MARKING HEAD makes it possible to mark the part while still set up in the machine, eliminating expensive secondary operations and additional equipment and labor.

### FEATURES & BENEFITS:

- **In-Carousel Design & Compact Size:** Easily positioned in tool magazine or turret without interfering with machine components or work piece.
- **Multi-Character Marking Letters & Numbers:** Up to 13 characters and 0.187 maximum character height.
- **Marks In Less Than 1 Second**
- **Adjustable and Uniform Marking Depth**
- **Precise Marking Location Repeatability**
- **Positive Locking**
- **Easy Type Change**
- **Accepts Blank Spacers**

### APPLICATIONS:

- **Designed to work in conjunction with CNC Machining and Turning Centers as well as any Manual Turning, Milling or Drilling Machines.**
- **Shank Sizes:** 3/4", 1.0" and MT3.
- **2 Stamp Holding Systems:** Integrated Type Holder or ER Collet Chuck to hold your own customized stamps.
- **Uses:** With the TAPMATIC MARKING HEAD you can mark:
  - Date**
  - Part Number**
  - Description**
  - Company Name etc.**on your work piece while still on your machine.

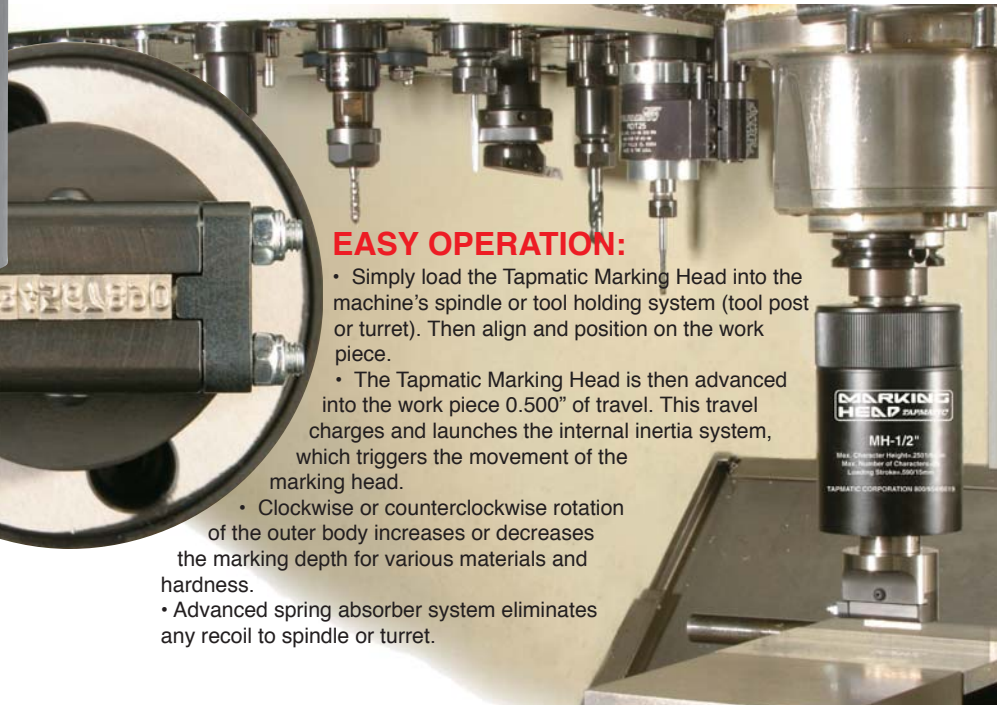

### EASY OPERATION:

- Simply load the Tapmatic Marking Head into the machine's spindle or tool holding system (tool post or turret). Then align and position on the work piece.
- The Tapmatic Marking Head is then advanced into the work piece 0.500" of travel. This travel charges and launches the internal inertia system, which triggers the movement of the marking head.
- Clockwise or counterclockwise rotation of the outer body increases or decreases the marking depth for various materials and hardness.
- Advanced spring absorber system eliminates any recoil to spindle or turret.

# MH 1/2 Type Holder Or ER Collet Chuck

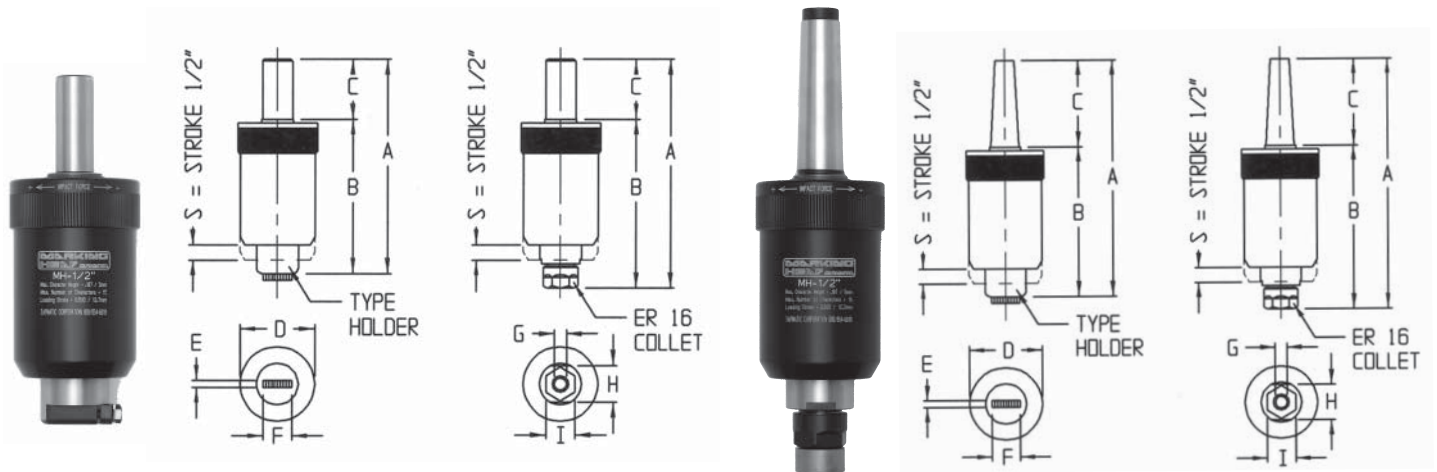

Style	Desc.	Part No.	Shank	A	B	C	D	E	F	Weight
Type Holder	MH 1/2	575075TH	3/4" SS	7 (177.6)	5.02 (127.6)	1.97 (50)	2.6 (66)	0.25 (6.4)	0.97 (24.5)	3.4 (1.54)
	MH-1/2	575010TH	1" SS	7 (177.6)	5.02 (127.6)	1.97 (50)	2.6 (66)	0.25 (6.4)	0.97 (24.5)	3.57 (1.62)
ER Collet	MH-1/2"-ER-16	57507516	3/4" SS	7.4 (188)	5.43 (138)	1.97 (50)	3.94 (100)	1.25 (32)	1 (25)	3.46 (1.57)
	MH 1/2"-ER-16	*57501016	1" SS	7.4 (188)	5.43 (138)	1.97 (50)	3.94 (100)	1.25 (32)	1 (25)	3.64 (1.65)
Type Holder	MH-1/2"	575003TH	MT3	7.94 (201.6)	4.63 (117.6)	3.31 (84)	2.6 (66)	0.25 (6.4)	0.97 (24.5)	3.86 (1.75)
ER Collet	MH-1/2"-ER-16	57500316	MT3	8.35 (212)	5.04 (128)	3.31 (84)	3.94 (100)	1.25 (32)	1 (25)	3.92 (1.78)

\*NOTE: CAT and BT shanks with 1" Bore shown on page 19 can be used with 57501016.

## Indexable Type Holder Inserts (optional)

Order No... 5750161  
Single Row  
Collet Holder Insert

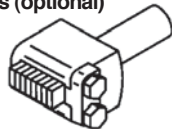

Order No....5750THI  
Single Row  
Type Holder Insert

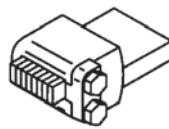

Custom Stamps Are Also  
Available On Request  
For Either Holding System.

TYPE Fits directly into "Type Holder" Style  
Marking Head or into above inserts.

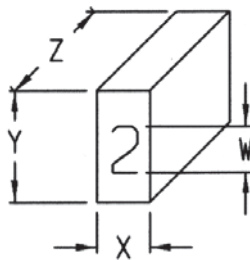

## Standard Steel Type Dimensions

W Character Height in	mm	X Width in	mm	Y Height in	mm	Z Length in	mm	No. of Characters Single Row MH-1/2"
.040	1	.063	1.6	.250	6.4	.875	22.2	13
.063	1.5	.063	1.6	.250	6.4	.875	22.2	13
.078	2	.078	2.0	.250	6.4	.875	22.2	10
.098	2.5	.094	2.4	.250	6.4	.875	22.2	9
.125	3	.126	3.2	.250	6.4	.875	22.2	7
.157	4	.157	4.0	.250	6.4	.875	22.2	6
.187	5	.189	4.8	.250	6.4	.875	22.2	5

Set 26 Letters	Part No.	Set 10 Numbers	Part No.	Blank Spacer	Part No.
.040	5707111006	.040	5707101000	.040	5707014002
.063	5707112009	.063	5707102003	.063	5707014002
.078	5707113001	.078	5707103006	.078	5707015005
.098	5707114004	.098	5707104009	.098	5707016008
.125	5707115007	.125	5707105001	.125	5707017000
.157	5707120001	.157	5707118008	.157	5707021008
.187	5707117002	.187	5707106004	.187	5708018003

TO ORDER INDIVIDUAL LETTERS, Please use set part number plus letter desired. Example: 570711106D