

SYNCHROFLEX Rigid Tap Drivers Safety And Operation Instructions

⚠️ WARNING To Avoid Serious Injury And Ensure Best Results For Your Tapping Operation, Please Read Carefully All Operator And Safety Instructions Provided For This Tapping Unit as well as all other safety instructions that are applicable, especially those for your machine tool.

⚠️ 1. Proper Clothing: The rotating spindle of a machine tool can snag loose fitting clothing, jewelry or long hair. **Never** wear jewelry, long sleeves, neckties, gloves or anything else that could become caught when operating a machine tool. Long hair **must** be restrained or netted to prevent it from becoming entangled in rotating spindle.

⚠️ 2. Proper Eye Protection: Always wear safety glasses with side shields to protect your eyes from flying particles.

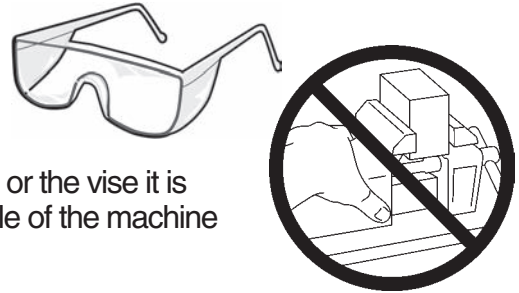

⚠️ 3. Proper Work Piece Fixturing: **Never** hold the work piece or the vise it is held in, by hand. The work piece **must** be clamped firmly to the table of the machine so that it cannot move, rotate or lift.

⚠️ 4. Always Be Aware Of The Potential Hazards Of A Machining Operation: Sometimes working with your machine can seem routine. You may find that you are no longer concentrating on the operation. A feeling of false security can lead to serious injury. Always be alert to the dangers of the machines with which you work. Always keep hands, body parts, clothing, jewelry and hair out of the areas of operation, when the machine spindle is rotating. Areas of operation include the immediate point of machining and all transmission components including the tapping attachment. Never bring your hand, other body parts or anything attached to your body into any of these areas until the machine spindle is completely stopped.

⚠️ 5. Be aware of any other applicable safety instructions / requirements.

Check List For Good Tapping

- ⚠️** 1. **Never** use this unit before reading all safety instructions for this attachment as well as the machine it is to be used on.
2. Is tap sharp and of correct design for current job?
3. Is tap in proper alignment with drilled hole?
4. Is machine speed correct?
5. Is machine feed correct?
5. Is machine stop set properly so tap does not bottom in work piece or fixture?
6. Is work piece held rigidly against rotation and upward movement?
7. Is drilled hole the correct size?
8. Is clearance between the drilled hole and tap sufficient at start position to allow the tap to clear the hole upon retraction?
9. Is the proper cutting fluid or coolant being used for lubricating the tap?
10. If a bottom hole is being tapped is there sufficient chip clearance?
11. Is the correct Tapmatic model for the specific job requirement being used? (Capacity should be reduced 25% for roll form taps.)

References for this Safety Information include but are not limited to:

American National Standards Institute
ANSI B11.8-1983 (Adopted May 31, 1983
by Department of Defense)

Society Of Manufacturing Engineers
Tool and Manufacturing Engineers Handbook
Volume 1 Machining
(Library of Congress Catalog No. 82-060312)

SYNCHROFLEX Installation Instructions

FEATURES & ADVANTAGES

- **Precision Machine Fixture:** Corrects the unavoidable deviations between the machine feed and the actual thread pitch of the tap during the rigid tapping cycle. Any deviation at all from the correct feed rate for the thread pitch or the precise hole location results in added wear on the tap. SynchroFlex allows the tap to reproduce itself exactly without this excessive wear. The results are greater tap life and improved thread quality.
- **Uses Steel Collets**
- **Coolant Through The Spindle:** SFTs are also available with balanced high pressure coolant system specified by adding "S" to part number. Pressure up to 80bar (1120psi)..
- **Program Using Your Standard Rigid Tapping Cycle.**
- **Tap Selection:** Some tap manufacturers offer "synchronous feed taps" with special geometry for use with rigid (solid) tap holders. These taps can cut over size when used with SynchroFlex tap holders. Switching to a standard tap corrects the problem and eliminates the extra cost of these special taps.

INSTALLING THE CNC ARBOR ON CYLINDRICAL SHANK

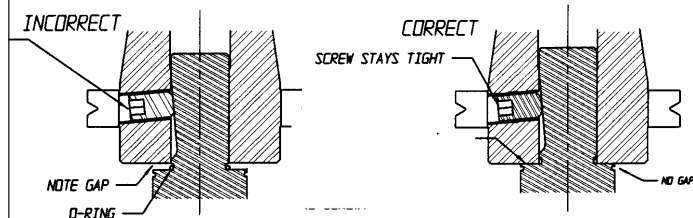

If screw is tightened without pushing CAT or BT over O-Ring, it leaves a gap between the shoulder of the straight shank and the bottom of the CAT or BT. When tapping a hole, the O-Ring compresses and the screw could become loose.

Push CAT or BT down against shoulder of the straight shank so that O-Ring goes inside the shank. Then tighten the locking screw.

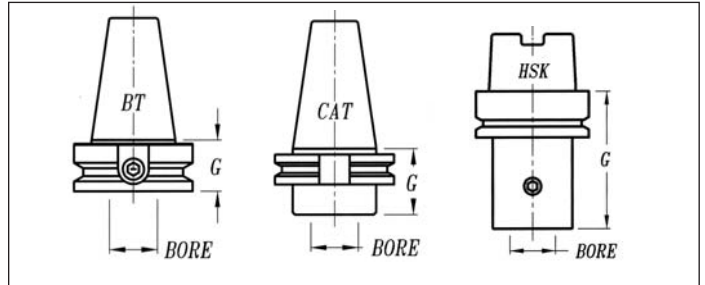

NC Arbors	Catalog No.	Bore	Weight	G
CAT-40	23951	1"	1.7 lb. (.7 kg.)	1.375 (35mm)
CAT-40	23947	25mm	1.7 lb. (.7 kg.)	1.375 (35mm)
CAT-45	23954	1"	3.6 lb. (1.6 kg.)	1.375 (35mm)
CAT-50	23953	1"	6 lb. (2.7 kg.)	1.375 (35mm)
CAT-50	23948	25mm	6 lb. (2.7 kg.)	1.375 (35mm)
BT-40	23952	1"	1.7 lb. (.7 kg.)	1.375 (35mm)
BT-40	23943	25mm	1.7 lb. (.7 kg.)	1.375 (35mm)
BT-45	23956	1"	4.5 lb. (2.0 kg.)	1.675 (42.5mm)
BT-50	23955	1"	8 lb. (3.6 kg.)	1.875 (47mm)
BT-50	23945	25mm	8 lb. (3.6 kg.)	1.875 (47mm)
HSK63A	23969	1"	3.5 Lb. (1.5 kg.)	3.020 (77mm)
HSK 80A	23973	1"	5.0 Lb. (2.1 kg.)	3.200 (81mm)
HSK 100 A	23971	1"	10.0 Lb. (4.2 kg.)	3.280 (83mm)

INSERTING TAP IN STEEL COLLET SPINDLE

Select the proper square drive collet for the tap (Steel collets must be ordered separately) Insert the collet into the nut being sure to fix pawl of collet nut with the seat of the collet for assembly and then mount into spindle.

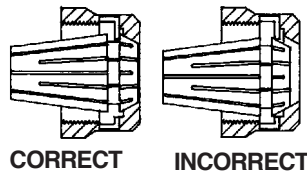

Next, Insert the tap and tighten collet nut firmly with the wrenches provided.

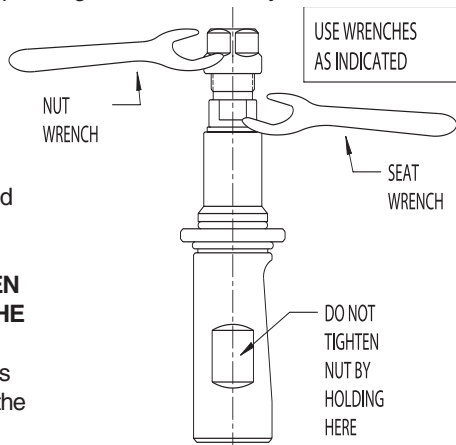

Be sure to use wrenches provided for tightening the collet nut. **DO NOT TIGHTEN BY GRIPPING THE SHANK OF THE ATTACHMENT** as this can damage the holder.

USING A TORQUE WRENCH TO TIGHTEN COLLET

A fixture is available to take the place of the "SEAT WRENCH" if you would like to use a torque wrench to tighten the collet. Order fixture... sftclampfix/1.

RECOMMENDED TIGHTENING TORQUE

Nut Size	Torque Max.
ER11	18Nm / 13 ft.-lbs.
ER16 Mini	24 Nm / 18 ft.-lbs.
ER20	40 Nm / 29 ft.-lbs.
ER25	130 Nm / 95 ft.-lbs.
ER40	200 Nm / 150 ft.-lbs.

IMPORTANT: Be sure to use square drive, "GB" type steel collets.

SYNCHROFLEX Installation Instructions

Standard ER Steel Collets For Inch Shank Taps



Series	Catalog No.	Collet Range	Tap Size
#11 Series	20929	.098-.118	#4-#6
	20930	.118-.142	
	20931	.137-.157	
	20932	.157-.177	#8
	20934	.177-.197	
	20933	.197-.217	
	20934	.177-.197	#10
	20935	.217-.236	
	20936	.236-.256	#12

Square Drive ER Steel Collets For Inch Tap Shanks

Order Series No.	Tap Size	Shank	Square	
#11	21000 #0-#6	.141	.110	
	21001 #8	.168	.131	
	21002 #10	.194	.152	
#16	21004 #0-#6	.141	.110	
	21005 #8	.168	.131	
	21006 #10	.194	.152	
	21008 #12	.220	.165	
	21010 1/4"	.255	.191	
	21012 5/16"	.318	.238	
	21014 7/16"	.323	.242	
	21019 #8	.168	.131	
#20	21020 #10	.194	.152	
	21021 #12	.220	.165	
	21022 1/4"	.255	.191	
	21023 5/16"	.318	.238	
	21024 7/16"	.323	.242	
	21025 1/2"	.367	.275	
	21026 3/8"	.381	.286	
	21027 1/16" pipe	.3125	.234	
	#25	21029 5/16"	.318	.238
		21030 7/16"	.323	.242
21032 1/2"		.367	.275	
21034 3/8"		.381	.286	
21036 9/16"		.429	.322	
21038 5/8"		.480	.360	
21040 11/16"		.542	.406	
21043 1/4" pipe		.562	.421	
21044 3/4"		.590	.442	
#40		21104 1/2"	.367	.275
	21105 3/8"	.381	.286	
	21106 9/16"	.429	.322	
	21107 5/8"	.480	.360	
	21108 11/16"	.542	.406	
	21109 3/4"	.590	.442	
	21110 13/16"	.652	.489	
	21111 7/8"	.697	.523	
	21112 15/16"	.760	.570	
	21113 1"	.800	.600	
	21117 1 1/8"	.896	.672	
	21114 1/4" pipe	.562	.421	
	21115 3/8" pipe	.700	.531	
21116 1/2" pipe	.687	.515		

Square Drive ER Collets For Metric Tap Shanks

Series	Order No.	Shank	Square	
#16	21085	4.5	3.4	
	21086	5.5	4.3	
	21087	6	4.9	
	21088	7	5.5	
	21089	8	6.2	
	21090	6.3	5	
	21091	7.1	5.6	
	21092	9	7	
	#20	21077	4.5	3.4
21078		5.5	4.3	
21079		6	4.9	
21080		7	5.5	
21081		8	6.2	
21082		9	7	
21083		10	8	
21084		11	9	
#25		21152	8.5	6.5
		21153	7	5.5
	21154	8	6.2	
	21155	9	7	
	21156	10	8	
	21157	11	9	
#40	21158	12	9	
	21159	14	11	
	21160	16	12	
	21123	14	11	
	21124	16	12	
	21125	18	14.5	
	21127	22	18	

Other Square Drive Metric Sizes Available On Request

Steel Collet Seals For Use With Coolant Through Steel Collet Models and Sealing Disk Nuts.

#20 Series Seals Size	Order No.
4.5-5mm (.177-.197)	70121-50
5-5.5mm (.197-.217)	70121-55
5.5-6mm (.217-.236)	70121-60
6-6.5mm (.236-.256)	70121-65
6.5-7mm (.256-.276)	70121-70
7-7.5mm (.276-.295)	70121-75
7.5-8mm (.295-.315)	70121-80
8-8.5mm (.315-.335)	70121-85
8.5-9mm (.335-.354)	70121-90
9-9.5mm (.354-.374)	70121-95
9.5-10mm (.374-.394)	70121-100
10-10.5mm (.394-.413)	70121-105
10.5-11mm (.413-.433)	70121-110
11-11.5mm (.433-.453)	70121-115
11.5-12mm (.453-.472)	70121-120
12-12.5mm (.472-.492)	70121-125

#25 Series Seals Size	Order No.
7-7.5mm (.276-.295)	70126-75
7.5-8mm (.295-.315)	70126-80
8-8.5mm (.315-.335)	70126-85
8.5-9mm (.335-.354)	70126-90
9-9.5mm (.354-.374)	70126-95
9.5-10mm (.374-.394)	70126-100
10-10.5mm (.394-.413)	70126-105
10.5-11mm (.413-.433)	70126-110
11-11.5mm (.433-.453)	70126-115
11.5-12mm (.453-.472)	70126-120
12-12.5mm (.472-.492)	70126-125
12.5-13mm (.492-.512)	70126-130
13-13.5mm (.512-.531)	70126-135
13.5-14mm (.531-.551)	70126-140
14-14.5mm (.551-.571)	70126-145
14.5-15mm (.571-.591)	70126-150
15-15.5mm (.591-.610)	70126-155
15.5-16mm (.610-.630)	70126-160

#40 Series Seals Size	Order No.
12.0-12.5 (.472-.492)	70141-125
13.5-14.0 (.531-.557)	70141-140
14.5-15.0 (.571-.591)	70141-150
15.5-16.0 (.610-.629)	70141-160
16.5-17.0 (.649-.669)	70141-170
17.5-18.0 (.689-.709)	70141-180
18.0-18.5 (.709-.729)	70141-185
19.5-20.0 (.768-.787)	70141-200
20.0-20.5 (.787-.807)	70141-205
23.5-24.0 (.925-.945)	70141-240

ER Collet Nuts For Use With Sealing Disc.
Collet shown here for reference only. Please order separately.

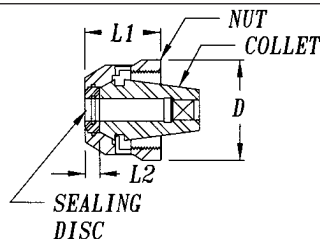

Included With B.C.S. Steel Collet Sealing Disc Nut For Use With SFT50, SFT75, SFT100

#20 Series Sealable Nut	70120
#25 Series Sealable Nut	70125
#40 Series Sealable Nut	70140

Tapmatic Also Offers Coolant Canal Sleeves For Coolant Along Outside of Tap

Please specify by tap shank diameter

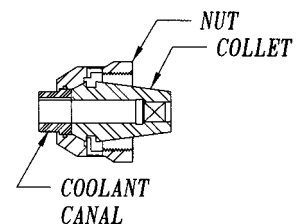

Repair Service: SYNCHROFLEX Rigid Tap Driver

Repair Service is available at...

Attention: Repair Department
Tapmatic Corporation
802 Clearwater Loop
Post Falls, ID 83854

To Expedite Repair: Return tool direct to Tapmatic Corporation, by United Parcel Service and enclose the following statement with your purchase order: "**Authorization given to repair and return tool without notification if total repair cost does not exceed 40% of the cost of a new tool.**" Tapmatic will repair the tool and call to request your credit card # for invoicing.

IMPORTANT: Be sure to return the tool complete with the tap chuck nut, back jaw and if the tool is a reversing unit, include stop arm. Otherwise, we will add these missing parts to every non-warranty repair.

Cost Notification: Tapmatic will FAX a cost notification to you, soliciting your approval before repairs are completed.

If it is determined that a tapping attachment cannot be repaired, at the customer's request, Tapmatic will return the disassembled parts. We are not able to reassemble tapping attachments using damaged or worn out parts.

Optional Return Procedure: Tools may also be returned for repair through your local Tapmatic Distributor. They will ship the tool to us and include instructions for the repair and return. You may already have an open account with them which facilitates the handling of invoicing.

Priority Service: Tapmatic services tapping attachments returned for repair in the order in which they are received. All tools will be evaluated and repaired within three weeks from the date they arrive subject to receiving the customer's approval to proceed with the repair.

Priority is given to the tools shipped to us by overnight or second day.

If a repair is sent to us by UPS ground or similar service it can also be given priority. Just call and let us know you need priority service and advise if you would like the tool returned to you by overnight or second day. In the interest of fairness, to all our customers, we ask that you approve return shipment by overnight or second day before we agree to upgrade your repair order to priority service. Typical turnaround, not including shipping time, for priority repairs is 3 days subject to receiving the customer's approval to proceed with the repair.

If we can answer any questions, please call our toll free number: 800 395-8231.



The Tapping Specialists

TAPMATIC CORPORATION: ISO 9001 CERTIFIED
802 Clearwater Loop, Post Falls, Idaho 83854
Phone: (208) 773-8048, (800) 854-6019, FAX: (208) 773-3021

TAPMATIC INTERNATIONAL CORPORATION
Alte Rheinstrasse, CH-9451 Kriessern, Switzerland
Phone: 011 41 71 757 5900, FAX: 011 41 71 757 5901



Distributed By:

#SFT/0407/NCG/1000